

Caratteristiche

Icematic introduce la nuova gamma di armadi di conservazione **EF**, nati per conservare al meglio ogni prodotto. Grande potenza, versatilità, facilità d'uso ed affidabilità sono le caratteristiche più importanti degli armadi **EF**.

- Nuova scheda elettronica con comandi soft touch , display ad alta luminosità, e icone di stato/Allarme multicolore
- Modelli ventilati, con impostazione di alta e bassa umidità
- Design ergonomico
- Efficienza energetica migliorata
- Ventilatori a basso consumo energetico
- Illuminazione led
- Spessore isolamento 70 mm
- Questo armadio è destinato all'utilizzo a temperatura ambiente fino a 40°C

OPTIONAL:

- Ruote
- HACCP recorder su SD memory card
- Versione pasticceria
- Apps Android monitoraggio con connessione Bluetooth



Features

Icematic presents the new storage cabinets **EF**, born to preserve perfectly every product. Great power, versatility and extreme reliability are the most important features of the new **EF** line.

- New soft touch control panel , Large LED display with multicolors icons state / alarm, high brightness display
- Ventilated models, with high and low humidity settings
- Ergonomic design
- Improved energy efficiency
- Low energy consumption fans
- LED lighting
- Insulation thickness 70 mm
- This appliance is intended for use in ambient temperature up to 40°C

OPTIONALS:

- Wheels
- HACCP recorder with SD memory card
- Pastry version
- Apps Android monitoring with connection Bluetooth

Temperatura esercizio Working Temperature

-24°C / -10°C

Armadio ad alte prestazioni - Heavy-duty cabinet

Capacità - Capacity

		
max 29	max 54	max 60
(Passo-Step 40 mm) Trays : Pastry 600 x 800 mm	(Passo-Step 140 mm) Bacinelle/Basin 360x165xH125	(Passo-Step 270 mm) Pozzetti Diam. 200 x H250

Caratteristiche - Features

Alimentazione Elettrica / Power supply	220-240 V / 1 / 50 Hz
Codice Prodotto / Code number	EF100 NV
Lunghezza esterna / Outside length	810 mm
Profondità / Depth	1045 mm
Altezza esterna / Height	2100-2170 mm
Volume netto / Net volume	625 l
Consumo energia / Energy Consumption (kW/year-anno) - [kW/24h]	(3590) - [9,84]
Indice efficienza energetica / Energy Efficiency Index (IEE)	78.82
Classe prestazioni / Classe climatic - Class of use / Climatic class	E - 5
Capacità / Capacity GN 2/1	29
Regolazione passo Teglie / Tray pitch regulation	10 mm
Compressore / Compressor	HERMETIC
Potenza Frigorifera / Refrigeration Power (-10°C/+45°C-EN12900)	1842 W
Fluido refrigerante / Refrigeration Fluid	800 g - R452A (GWP2141)
Ton CO2 equiv.	1,71
Potenza assorbita / Absorbed power	1160 W - 6,0 A
Sbrinamento / Defrost	Automatic - Hot Gas
Peso netto/lordo net/gross Weight	169 / 182 kg
Dati spedizione / Shipment data	866 x 1166 x 2270 mm - 215 Kg ca.
Accessori in dotazione - Supplied Accessories	
Coppia Guide / Pairs of Slides PAST	5

Dimensioni- Dimensions

Vista frontale
Front view

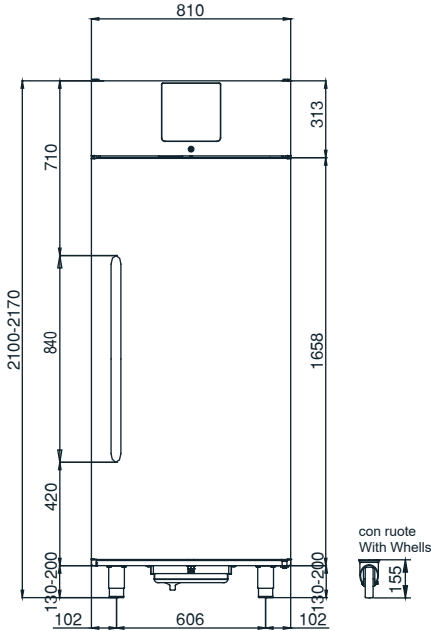

Vista laterale
Lateral view

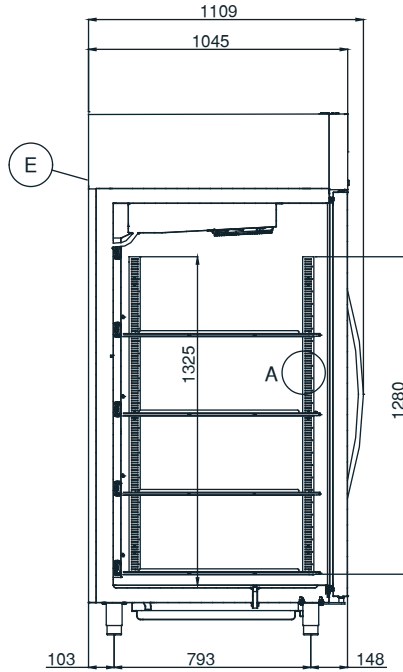

Vista superiore
Top view

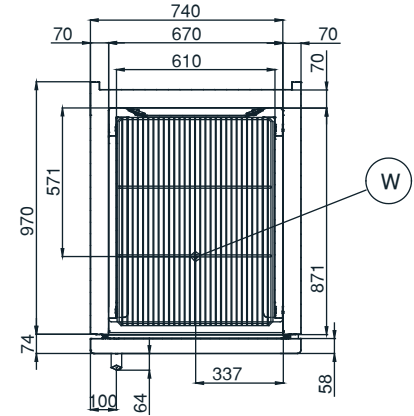

Pasticceria
Pastry

max 42
Teglie/Trays
Passo/Step
30 mm
(600x800)

(A)

127 fori
passo 10 mm

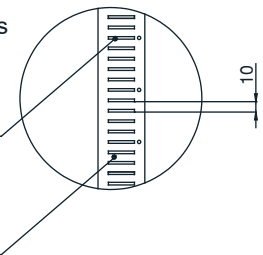

E Alimentazione elettrica
Electrical cable supply

W Scarico acqua
Water discharge

Quadro comandi / Control panel

evconnect

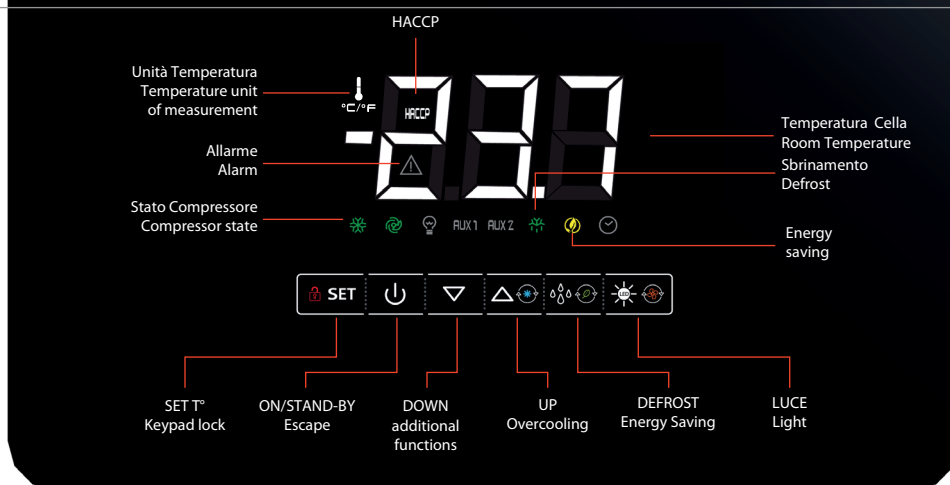

(optional)

EF 100 NV 220-240 V/1N/50Hz - Armadio Refrigerato Ventilato / Ventilated Refrigerated Cabinet